



University of Alabama
School of Theatre and Dance
Marian Galloway Theatre

Teila Vochatzer
SCENIC DESIGNER

The Color Purple
GROUND PLAN

Directed by

Lighting Designer

Sound Designer

Technical Director

Scale
1/8" = 1'

General Notes

1. TRIM HEIGHT FOR WOODEN WALLS ARE SUBJECT TO CHANGE.

This drawing is confidential. The reproduction or use of ideas, arrangements, designs, and plans are prohibited without written consent of Teila Vochatzer.

Written dimensions will always override scale should a conflict arise.

Responsibility falls solely on the vendors to notify Teila Vochatzer of any discrepancies between this drawing and actual dimensions.

This drawing represents concepts and suggestions only. The design team is not responsible nor held liable for the structural, mechanical or electrical execution of this drawing. Any structural components within this drawing must be approved by a qualified engineer before installation begins. Furthermore any other work done is to be performed by qualified personnel only.

Equipment and installation must conform to all local and federal codes and fire safety regulations.

Plate No.

1 OF 10

September 28, 2021

- 25 CYC (24'-0" X 47'-0"), TRIM @ 0"
- 24 TRAVELER W/ FULLNESS (24' X 47'), TRIM @ 0"
- 23 FLAT BORDER (12' X 47'), TRIM @ 23'-0"
- 22 FLAT LEGS, (12' X 24'), TRIM @ 0", 15' - 7 1/2" FROM CL
- 21 WOODEN WALL A & F, TRIM @ 1'-4"
- 20 FLAT BORDER (8' X 47'), TRIM @ 23'-0"
- 19 CROSS_TRIM @ 11'-6"
- 18 CROSS_TRIM @ 17'-11"
- 17 FLAT BORDER (8' X 47'), TRIM @ 23'-1"
- 16 WOODEN WALL G, TRIM @ 10'-10"
- 15 FLAT BORDER (8' X 47'), TRIM @ 23'-11"
- 14 FLAT BORDER (8' X 47'), TRIM @ 23'-11"
- 13 WOODEN WALL H & I, TRIM @ 10'-5"
- 12 FLAT BORDER (8' X 47'), TRIM @ 23'-0"
- 11 WOODEN WALL B & D, TRIM @ 10'-6"
- 10 FLAT BORDER (8' X 47'), TRIM @ 20'-10"
- 9 WOODEN WALL C & E, TRIM @ 3"
- 8 FLAT BORDER (8' X 47'), TRIM @ 18'-4"
- 7 WOODEN BORDER, TRIM @ 12'-0"

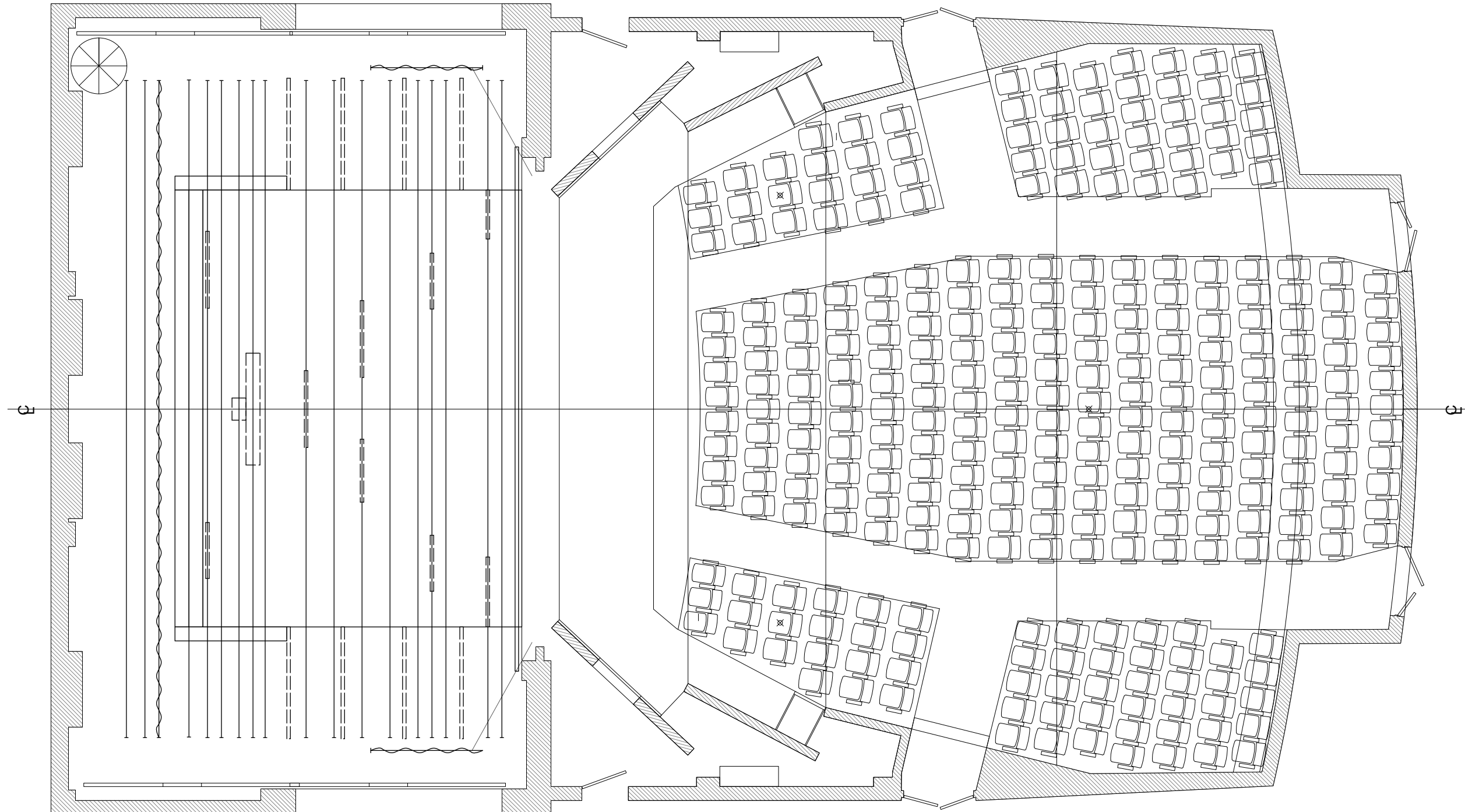



University of Alabama
School of Theatre and Dance
Marian Galloway Theatre

Teila Vochatzer
SCENIC DESIGNER

The Color Purple
SECTION

Directed by

Lighting Designer

Sound Designer

Technical Director

Scale
1/8" = 1'

General Notes

1. TRIM FOR SOFT GOODS, & WOODEN WALLS IS SUBJECT TO CHANGE.

This drawing is confidential. The reproduction or use of ideas, arrangements, designs, and plans are prohibited without written consent of Teila Vochatzer.

Written dimensions will always override scale should a conflict arise.

Responsibility falls solely on the vendors to notify Teila Vochatzer of any discrepancies between this drawing and actual dimensions.

This drawing represents concepts and suggestions only. The design team is not responsible nor held liable for the structural, mechanical or electrical execution of this drawing. Any structural components within this drawing must be approved by a qualified engineer before installation begins. Furthermore any other work done is to be performed by qualified personnel only.

Equipment and installation must conform to all local and federal codes and fire safety regulations.

Plate No.

2 OF 10

September 28, 2021

- 25 CYC (24'-0" X 47'-0"), TRIM @ 0"
- 24 TRAVELER W/ FULLNESS (24' X 47'), TRIM @ 0"
- 23 FLAT BORDER (12' X 47'), TRIM @ 23'-0"
- 22 FLAT LEGS, (12' X 24"), TRIM @ 0", 15" - 7' 1/2" FROM CL
- 21 WOODEN WALL A & F, TRIM @ 1'-4"
- 20 FLAT BORDER (8' X 47'), TRIM @ 23'-0"
- 19 CROSS, TRIM @ 11'-6"
- 18 CROSS, TRIM @ 17'-11"
- 17 FLAT BORDER (8' X 47'), TRIM @ 23'-1"
- 16 WOODEN WALL G, TRIM @ 10'-10"
- 15 WOODEN WALL H & I, TRIM @ 10'-5"
- 14 FLAT BORDER (8' X 47'), TRIM @ 23'-11"
- 13 WOODEN WALL J, TRIM @ 10'-5"
- 12 FLAT BORDER (8' X 47'), TRIM @ 23'-0"
- 11 WOODEN WALL K & L, TRIM @ 10'-10"
- 10 WOODEN WALL M & N, TRIM @ 10'-9"
- 9 FLAT BORDER (8' X 47'), TRIM @ 20'-10"
- 8 WOODEN WALL O & P, TRIM @ 10'-10"
- 7 WOODEN WALL Q & R, TRIM @ 18'-4"
- 6 WOODEN WALL S & T, TRIM @ 12'-0"
- 5 WOODEN WALL U & V, TRIM @ 10'-10"
- 4 WOODEN WALL W & X, TRIM @ 3"
- 3 FLAT BORDER (8' X 47'), TRIM @ 18'-4"
- 2 WOODEN WALL Y & Z, TRIM @ 12'-0"
- 1 WOODEN WALL AA & AB, TRIM @ 12'-0"

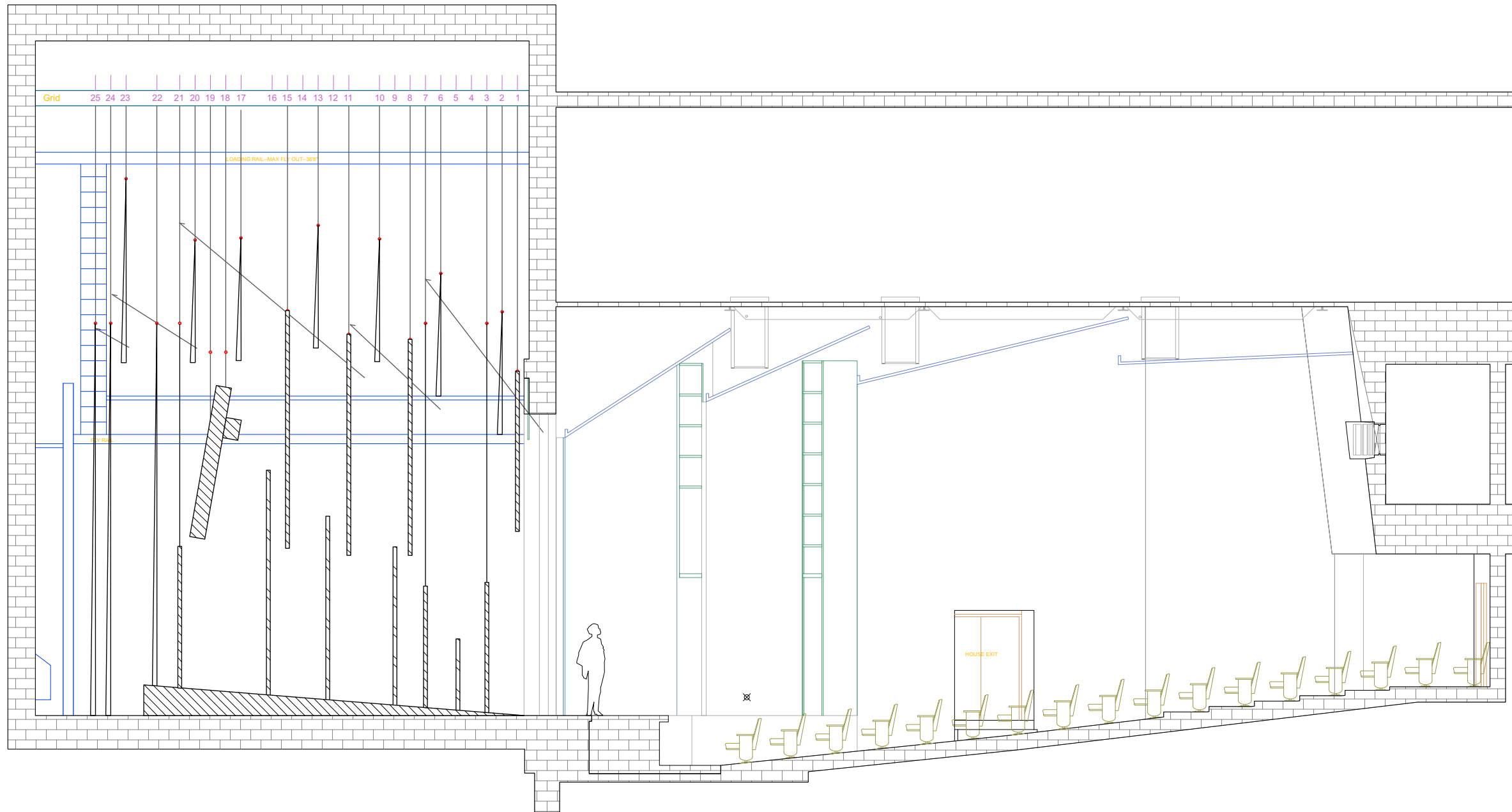



University of Alabama
School of Theatre and Dance
Marian Gallaway Theatre

Teila Vochatzer
SCENIC DESIGNER

The Color Purple
RAKED PLATFORM

Directed by

Lighting Designer

Sound Designer

Technical Director

Scale
1/4" = 1'

General Notes

1. SHOULD BE
SMOOTH PLANKS
W/ NO GAPS & WILL
BE PAINTED TO LOOK
ROUGH.

This drawing is confidential. The reproduction or use of ideas, arrangements, designs, and plans are prohibited without written consent of Teila Vochatzer.

Written dimensions will always override scale should a conflict arise.

Responsibility falls solely on the vendors to notify Teila Vochatzer of any discrepancies between this drawing and actual dimensions.

This drawing represents concepts and suggestions only. The design team is not responsible nor held liable for the structural, mechanical or electrical execution of this drawing. Any structural components within this drawing must be approved by a qualified engineer before installation begins. Furthermore any other work done is to be performed by qualified personnel only.

Equipment and installation must conform to all local and federal codes and fire safety regulations.

Plate No.

3 OF 10

Septemeber 28, 2021

1 **SIDE VIEW**
Scale: 1/4" = 1'-0"

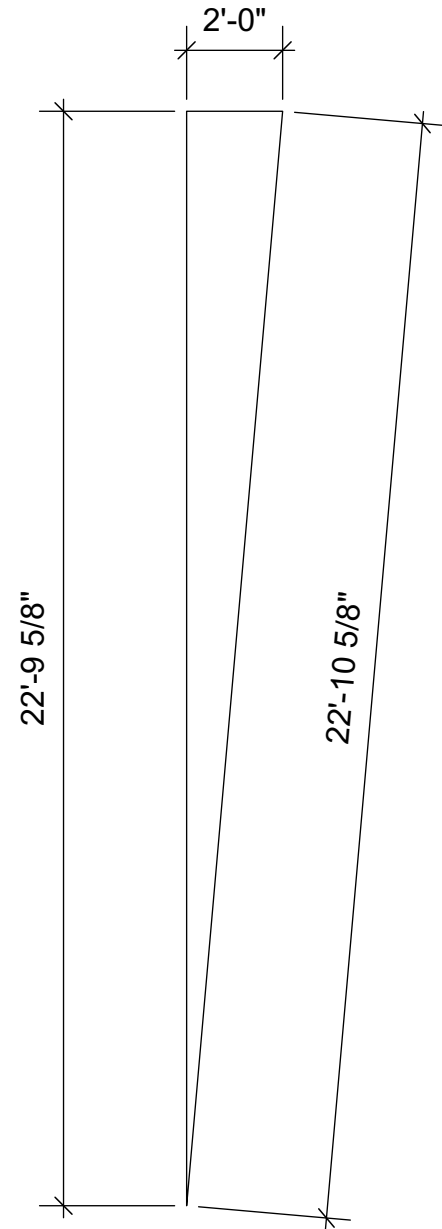

2 **BACK VIEW**
Scale: 1/4" = 1'-0"

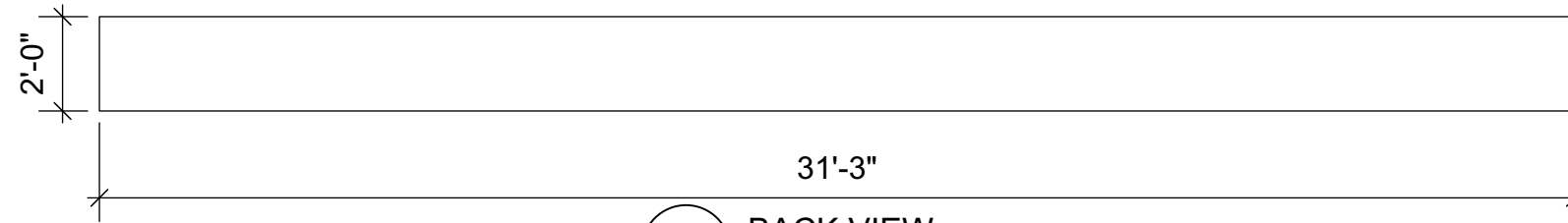

3 **TOP VIEW**
Scale: 1/4" = 1'-0"

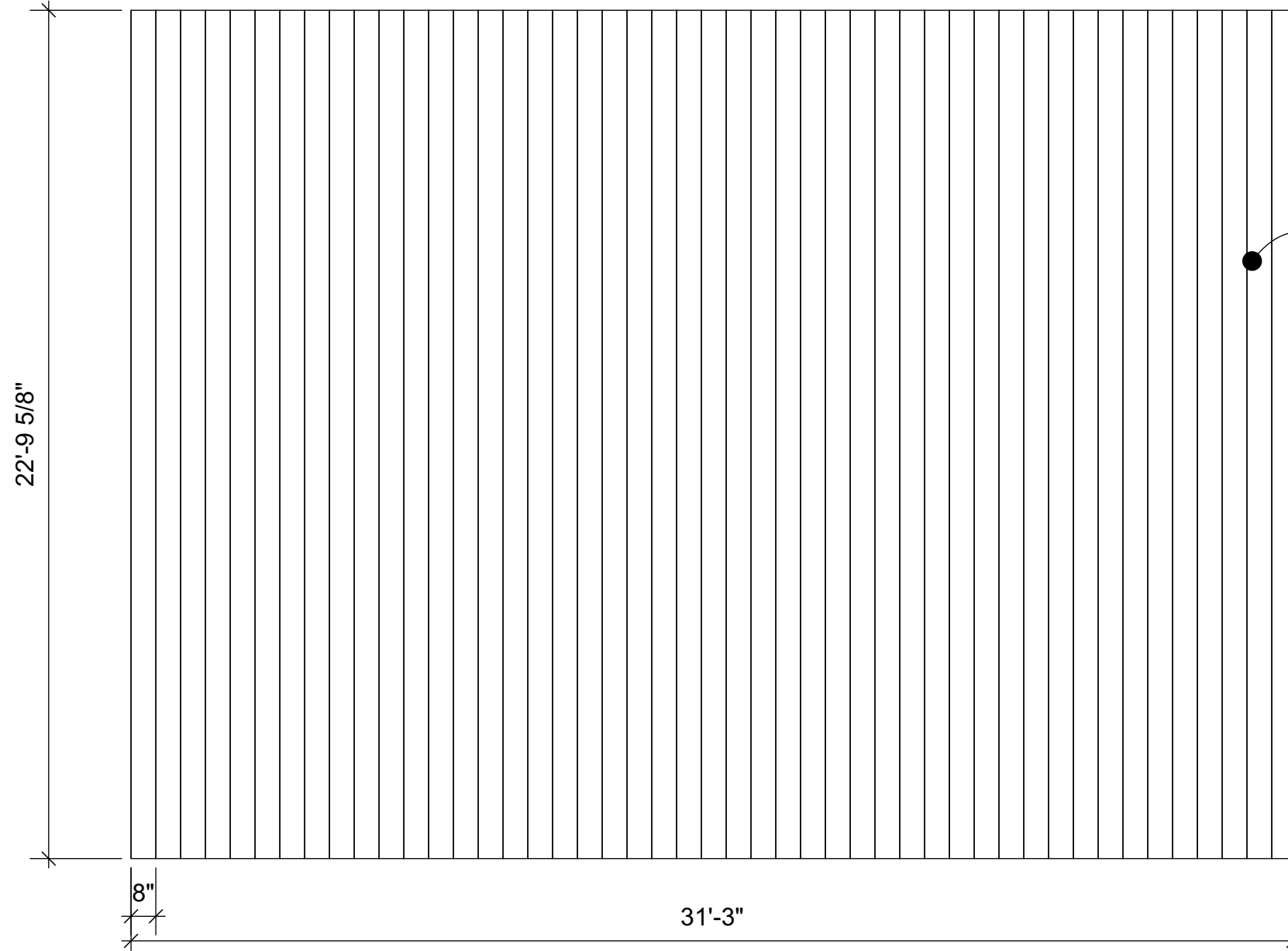

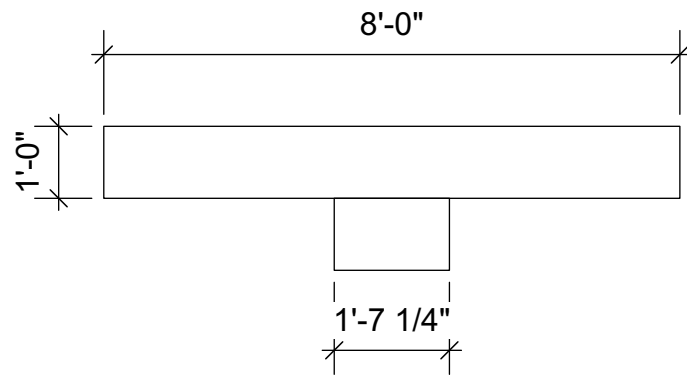

1 TOP VIEW
Scale: 3/8" = 1'-0"

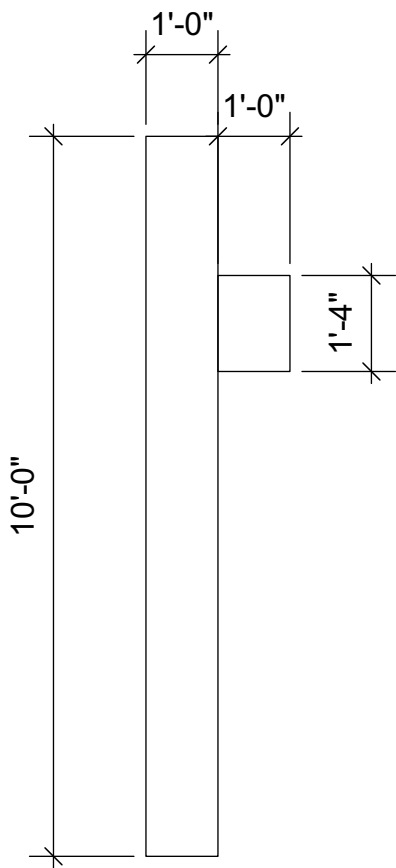

3 SIDE VIEW
Scale: 3/8" = 1'-0"

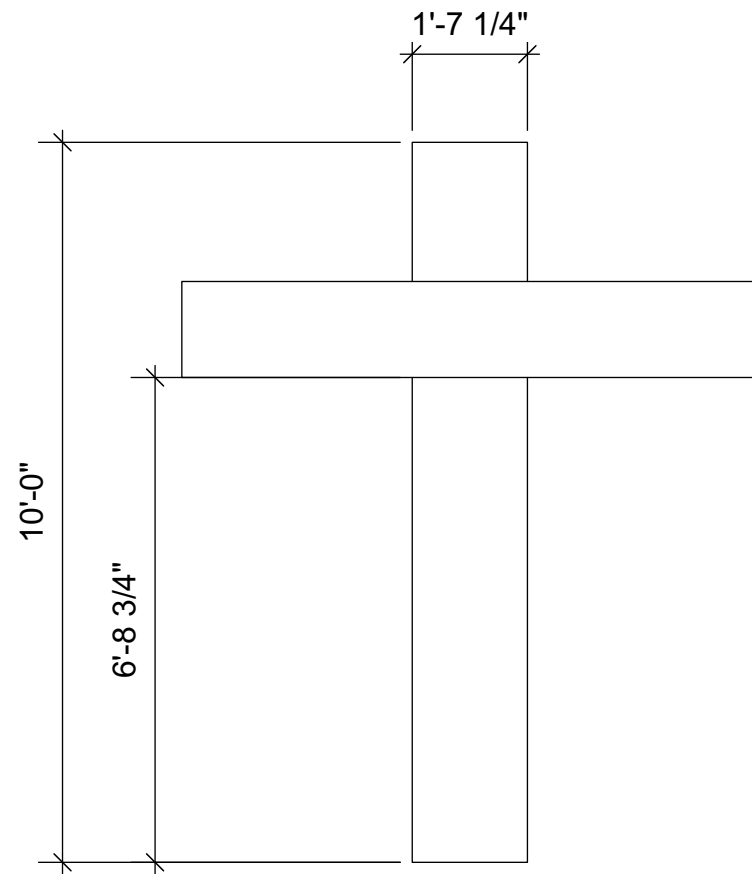

2 FRONT VIEW
Scale: 3/8" = 1'-0"

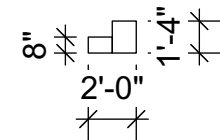

9 SIDE VIEW OF US STAIR UNIT
Scale: 1/8" = 1'-0"

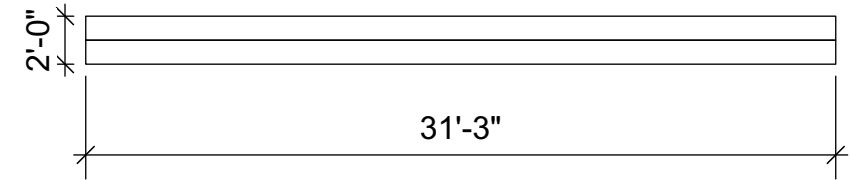

4 TOP VIEW OF US STAIR UNIT
Scale: 1/8" = 1'-0"

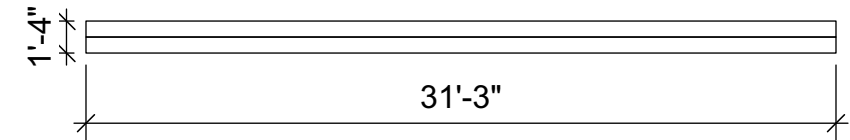

5 FRONT VIEW OF US STAIR UNIT
Scale: 1/8" = 1'-0"

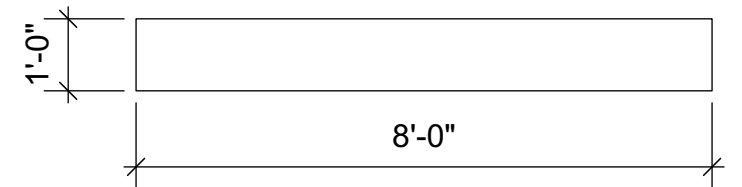

6 TOP VIEW OF SIDE STEPS
Scale: 3/8" = 1'-0"

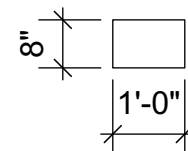

8 SIDE VIEW OF SIDE STEPS
Scale: 3/8" = 1'-0"

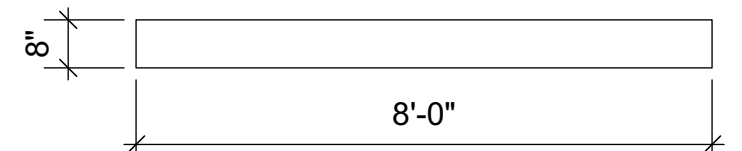

7 FRONT VIEW OF SIDE STEPS
Scale: 3/8" = 1'-0"



University of Alabama
School of Theatre and Dance
Marian Galloway Theatre

Teila Vochatzer
SCENIC DESIGNER

The Color Purple

CROSS & STEP UNITS

Directed by

Lighting Designer

Sound Designer

Technical Director

Scale
1/4" = 1'
UNLESS OTHERWISE NOTED

General Notes

- CROSS SHOULD BE CONSTRUCTED OUT OF ROUGH WOOD.
- STEP UNITS CAN BE PULLED.

This drawing is confidential. The reproduction or use of ideas, arrangements, designs, and plans are prohibited without written consent of Teila Vochatzer.

Written dimensions will always override scale should a conflict arise.

Responsibility falls solely on the vendors to notify Teila Vochatzer of any discrepancies between this drawing and actual dimensions.

This drawing represents concepts and suggestions only. The design team is not responsible nor held liable for the structural, mechanical or electrical execution of this drawing. Any structural components within this drawing must be approved by a qualified engineer before installation begins. Furthermore any other work done is to be performed by qualified personnel only.

Equipment and installation must conform to all local and federal codes and fire safety regulations.

Plate No.

4 OF 10

Septemeber 28, 2021



University of Alabama
School of Theatre and Dance
MARIAN GALLAWAY THEATRE

Teila Vochatzer
SCENIC DESIGNER

The Color Purple
WOODEN BORDER

Directed by

Lighting Designer

Sound Designer

Technical Director

Scale
1/4" = 1'

General Notes

1. SMOOTH WOOD PAINTED TO LOOK WORN & ROUGH.
2. WOOD THAT HAS ROUGH EGDE SHOULD BE CUT OR BROKEN.

This drawing is confidential. The reproduction or use of ideas, arrangements, designs, and plans are prohibited without written consent of Teila Vochatzer.

Written dimensions will always override scale should a conflict arise.

Responsibility falls solely on the vendors to notify Teila Vochatzer of any discrepancies between this drawing and actual dimensions.

This drawing represents concepts and suggestions only. The design team is not responsible nor held liable for the structural, mechanical or electrical execution of this drawing. Any structural components within this drawing must be approved by a qualified engineer before installation begins. Furthermore any other work done is to be performed by qualified personnel only.

Equipment and installation must conform to all local and federal codes and fire safety regulations.

Plate No.

5 OF 10

Septemeber 28, 2021

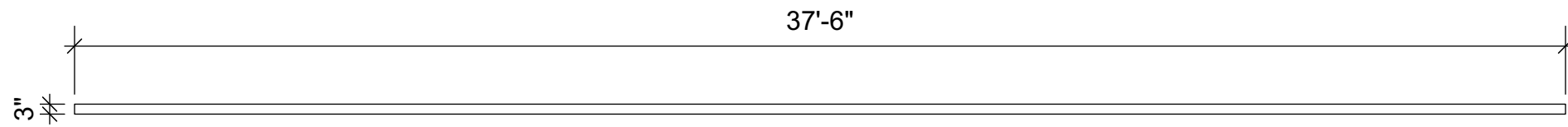

2 **TOP VIEW OF WOODEN BORDER**
Scale: 1/4" = 1'-0"

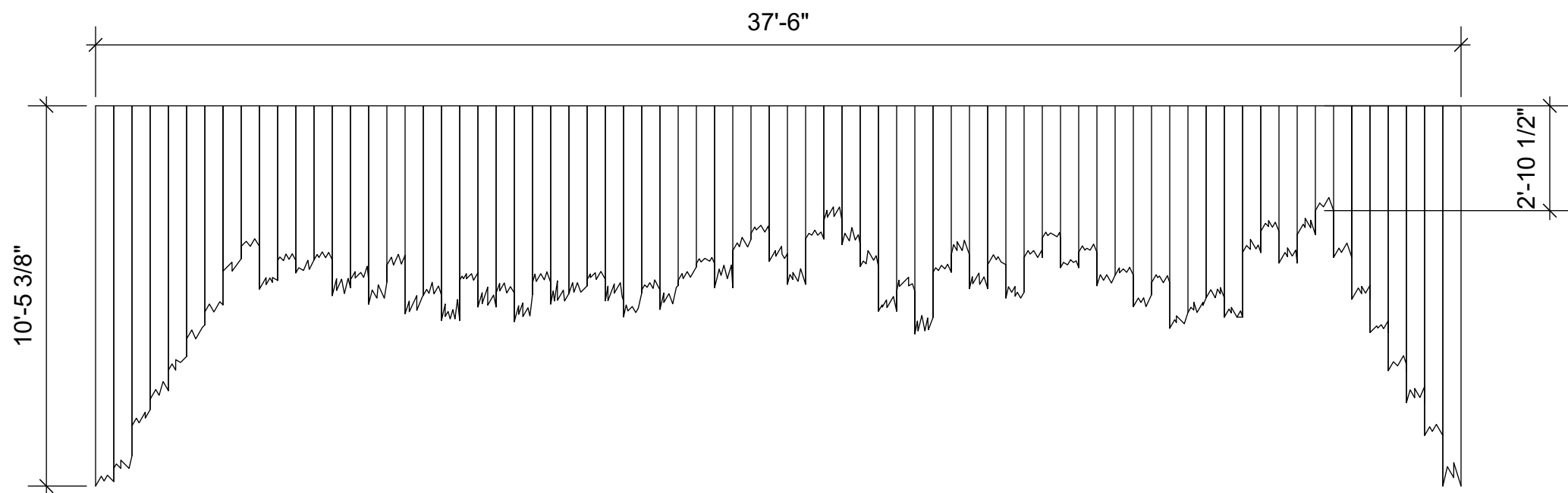

1 **FRONT VIEW**
Scale: 1/4" = 1'-0"

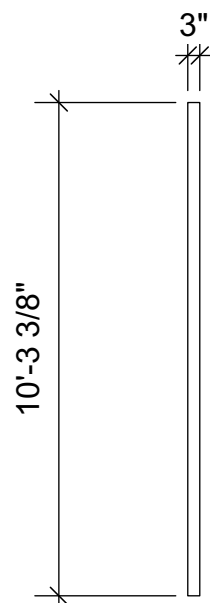

3 **SIDE VIEW OF WOODEN BORDER**
Scale: 1/4" = 1'-0"



University of Alabama
School of Theatre and Dance
MARIAN GALLAWAY THEATRE

Teila Vochatzer
SCENIC DESIGNER

The Color Purple

WALLS A-C

Directed by

Lighting Designer

Sound Designer

Technical Director

Scale
1/2" = 1'

General Notes

1. WALLS WILL BE SMOOTH WOOD & PAINTED TO LOOK WORN & ROUGH.
2. WOOD SHOULD BE CUT OR BROKEN TO LOOK ROUGH ON EDGES.
3. WALLS WILL BE RIGGED ON A TRACK FOR MOVEMENT ACROSS THE STAGE.

This drawing is confidential. The reproduction or use of ideas, arrangements, designs, and plans are prohibited without written consent of Teila Vochatzer.

Written dimensions will always override scale should a conflict arise.

Responsibility falls solely on the vendors to notify Teila Vochatzer of any discrepancies between this drawing and actual dimensions.

This drawing represents concepts and suggestions only. The design team is not responsible nor held liable for the structural, mechanical or electrical execution of this drawing. Any structural components within this drawing must be approved by a qualified engineer before installation begins. Furthermore any other work done is to be performed by qualified personnel only.

Equipment and installation must conform to all local and federal codes and fire safety regulations.

Plate No.

6 of 10

September 28, 2021

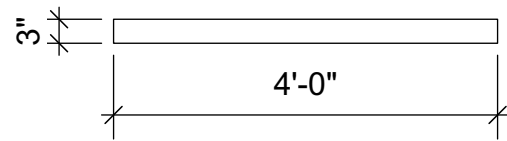

1 TOP VIEW OF WALL A
Scale: 1/2" = 1'-0"

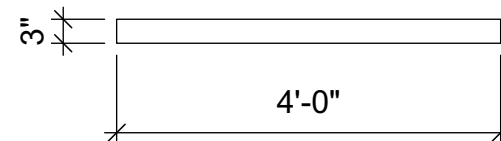

4 TOP VIEW OF WALL B
Scale: 1/2" = 1'-0"



7 TOP VIEW OF WALL C
Scale: 1/2" = 1'-0"

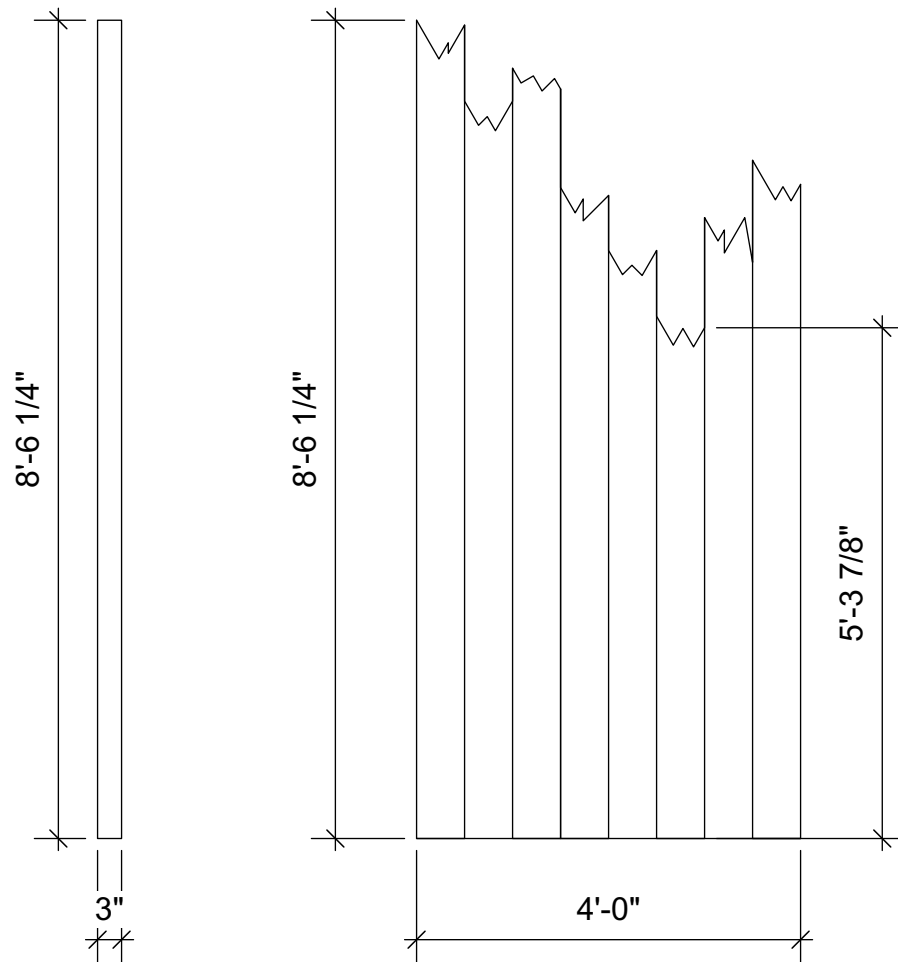

2 SIDE VIEW OF WALL A
Scale: 1/2" = 1'-0"

3 WALL A FRONT VIEW
Scale: 1/2" = 1'-0"

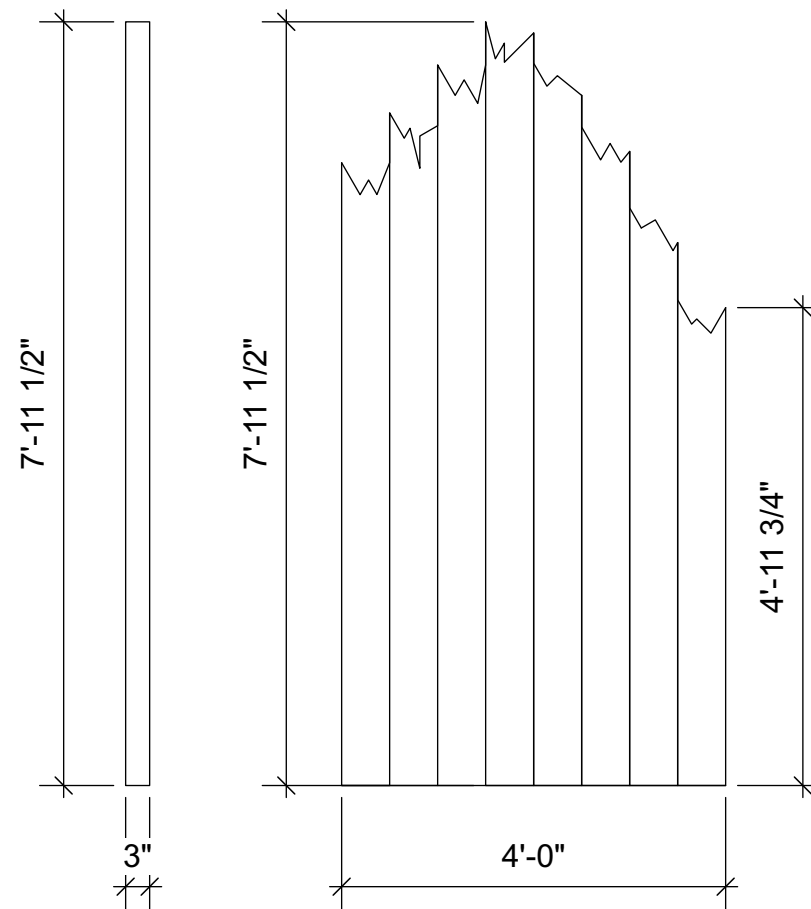

5 SIDE VIEW OF WALL B
Scale: 1/2" = 1'-0"

6 FRONT VIEW OF WALL B
Scale: 1/2" = 1'-0"

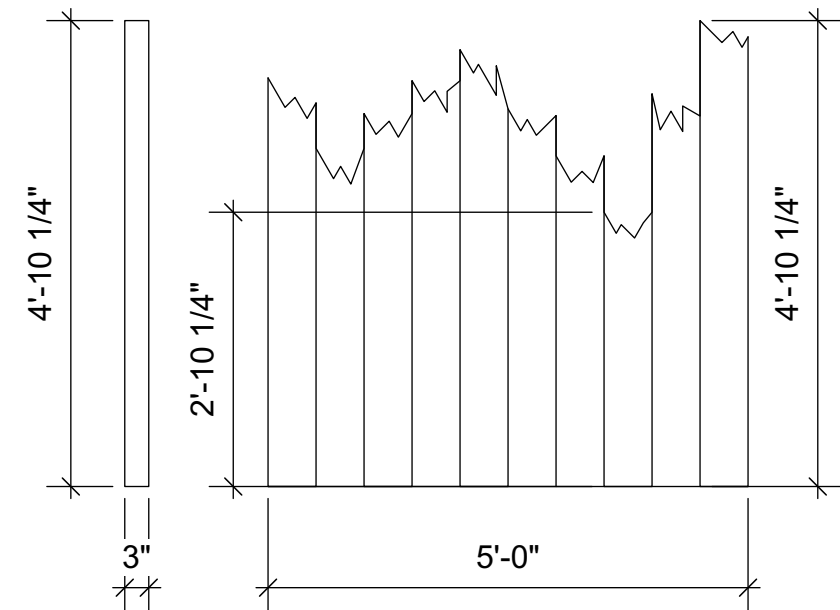

8 SIDE VIEW OF WALL C
Scale: 1/2" = 1'-0"

9 FRONT VIEW OF WALL C
Scale: 1/2" = 1'-0"



University of Alabama
School of Theatre and Dance
MARIAN GALLAWAY THEATRE

Teila Vochatzer
SCENIC DESIGNER

The Color Purple

WALLS D-F

Directed by

Lighting Designer

Sound Designer

Technical Director

Scale
1/2" = 1'

General Notes

1. WALLS WILL BE SMOOTH WOOD & PAINTED TO LOOK WORN & ROUGH.
2. WOOD SHOULD BE CUT OR BROKEN TO LOOK ROUGH ON EDGES.
3. WALLS WILL BE RIGGED ON A TRACK FOR MOVEMENT ACROSS THE STAGE.

This drawing is confidential. The reproduction or use of ideas, arrangements, designs, and plans are prohibited without written consent of Teila Vochatzer.

Written dimensions will always override scale should a conflict arise.

Responsibility falls solely on the vendors to notify Teila Vochatzer of any discrepancies between this drawing and actual dimensions.

This drawing represents concepts and suggestions only. The design team is not responsible nor held liable for the structural, mechanical or electrical execution of this drawing. Any structural components within this drawing must be approved by a qualified engineer before installation begins. Furthermore any other work done is to be performed by qualified personnel only.

Equipment and installation must conform to all local and federal codes and fire safety regulations.

Plate No.

7 OF 10

September 28, 2021

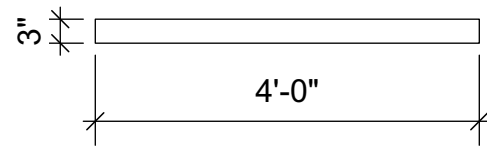

1 TOP VIEW OF WALL D
Scale: 1/2" = 1'-0"

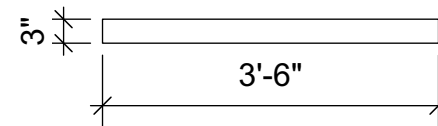

4 TOP VIEW OF WALL E
Scale: 1/2" = 1'-0"

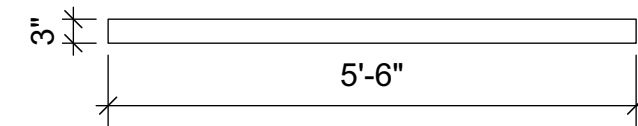

7 TOP VIEW OF WALL F
Scale: 1/2" = 1'-0"

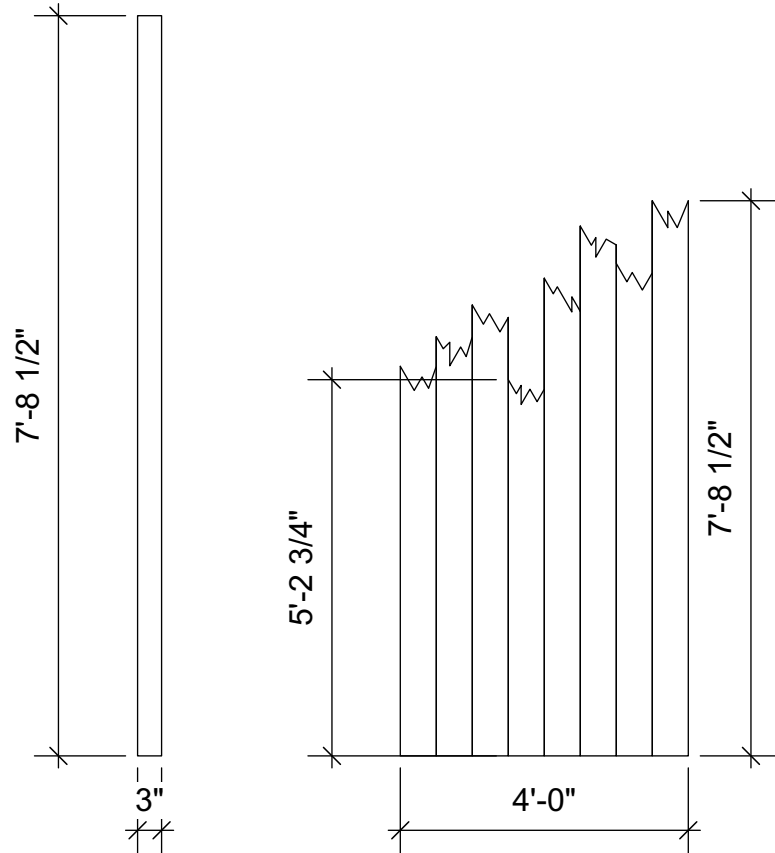

2 SIDE VIEW OF WALL D
Scale: 1/2" = 1'-0"

3 FRONT VIEW OF WALL D
Scale: 3/8" = 1'-0"

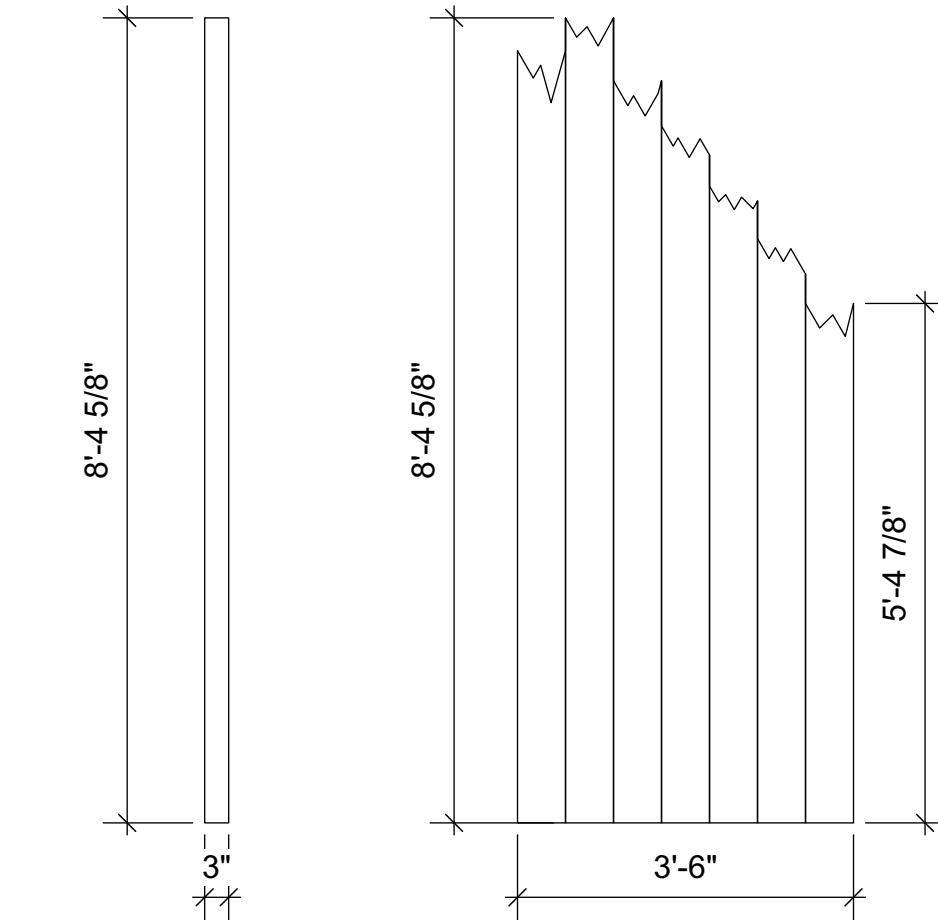

5 SIDE VIEW OF WALL E
Scale: 1/2" = 1'-0"

6 FRONT VIEW OF WALL E
Scale: 1/2" = 1'-0"

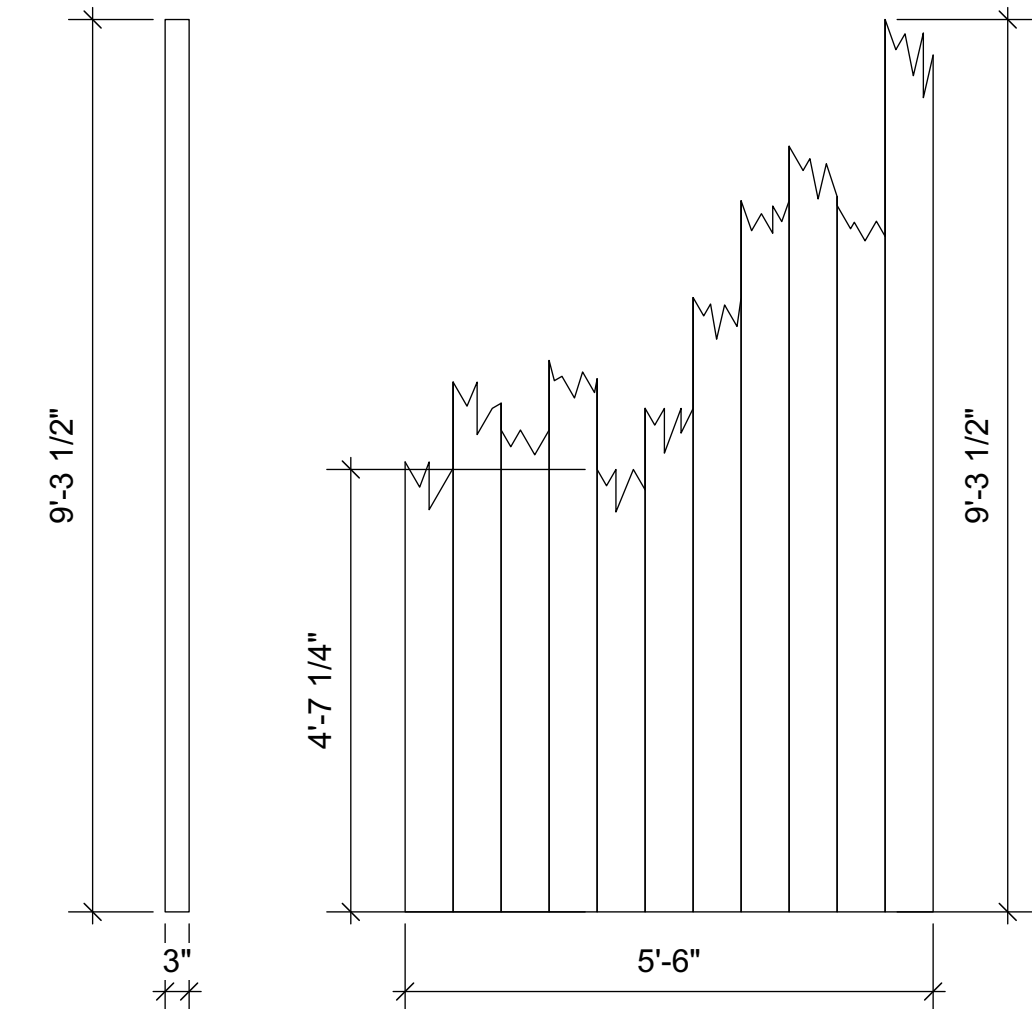

8 SIDE VIEW OF WALL F
Scale: 1/2" = 1'-0"

9 FRONT VIEW OF WALL F
Scale: 1/2" = 1'-0"



University of Alabama
School of Theatre and Dance
MARIAN GALLAWAY THEATRE

Teila Vochatzer
SCENIC DESIGNER

The Color Purple
WALLS G-I

Directed by

Lighting Designer

Sound Designer

Technical Director

Scale
1/2" = 1'

General Notes

1. WALLS WILL BE SMOOTH WOOD & PAINTED TO LOOK WORN & ROUGH.
2. WOOD SHOULD BE CUT OR BROKEN TO LOOK ROUGH ON EDGES.
3. WALLS WILL BE RIGGED ON A TRACK FOR MOVEMENT ACROSS THE STAGE.

This drawing is confidential. The reproduction or use of ideas, arrangements, designs, and plans are prohibited without written consent of Teila Vochatzer.

Written dimensions will always override scale should a conflict arise.

Responsibility falls solely on the vendors to notify Teila Vochatzer of any discrepancies between this drawing and actual dimensions.

This drawing represents concepts and suggestions only. The design team is not responsible nor held liable for the structural, mechanical or electrical execution of this drawing. Any structural components within this drawing must be approved by a qualified engineer before installation begins. Furthermore any other work done is to be performed by qualified personnel only.

Equipment and installation must conform to all local and federal codes and fire safety regulations.

Plate No.

8 of 10

September 28, 2021

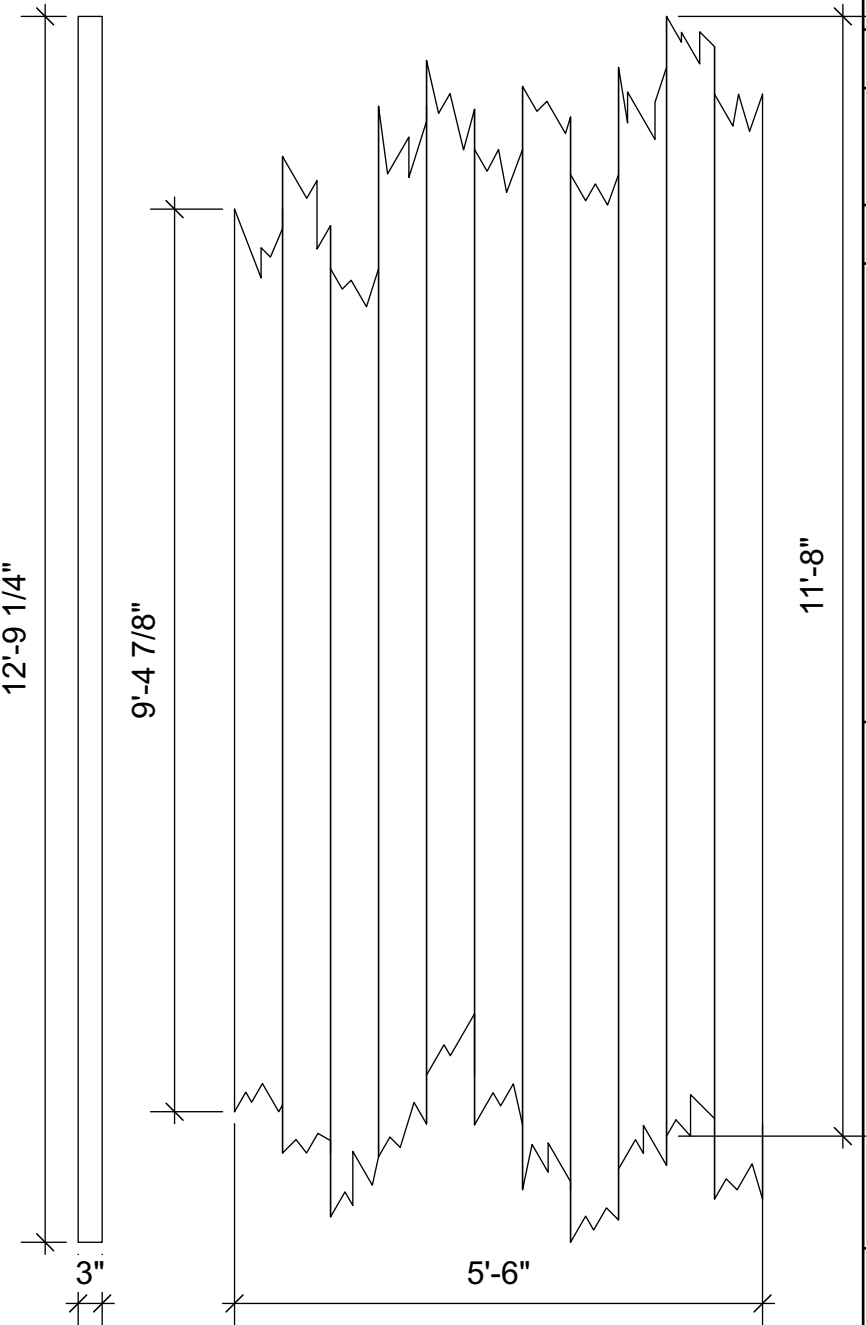
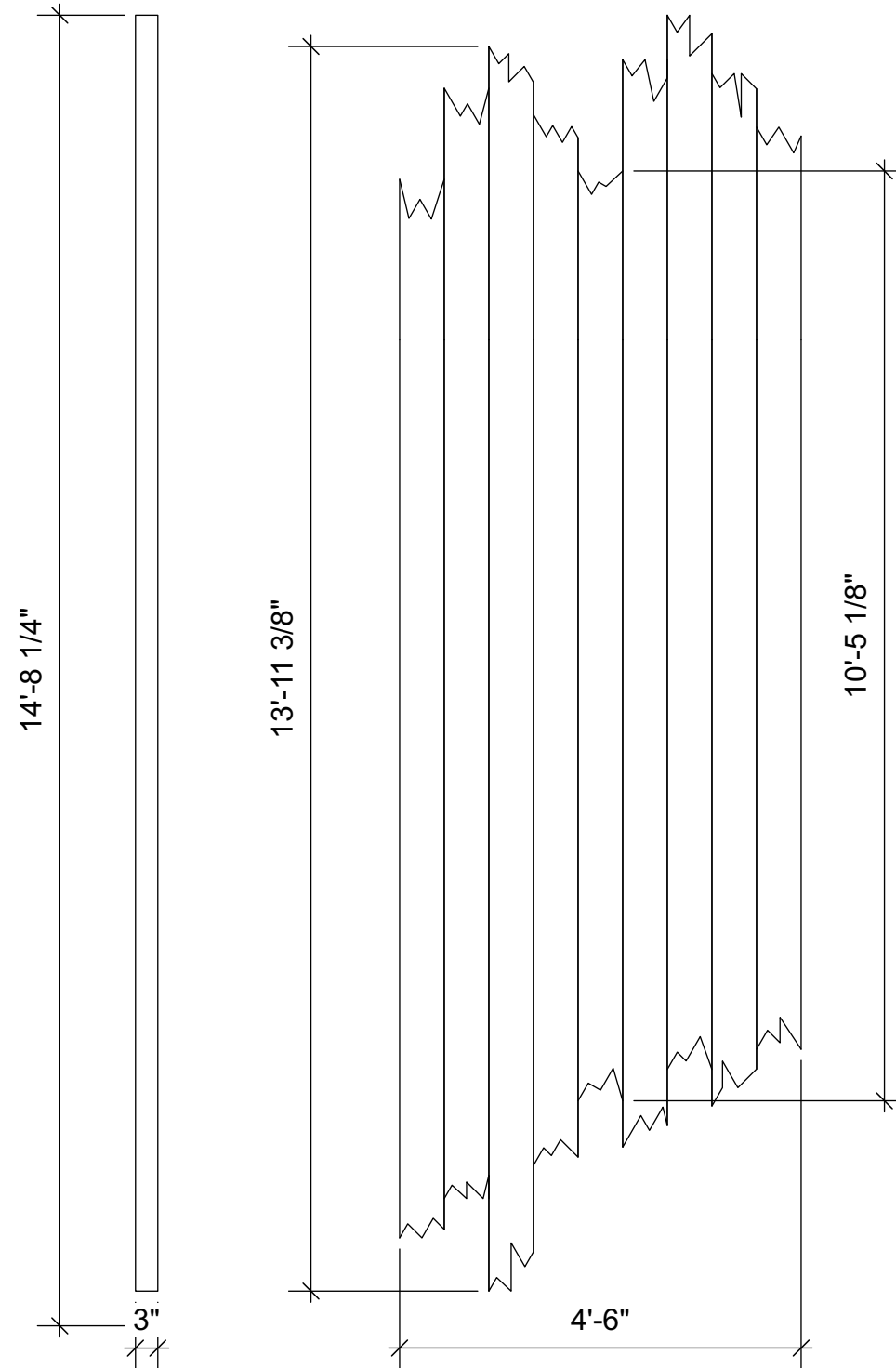
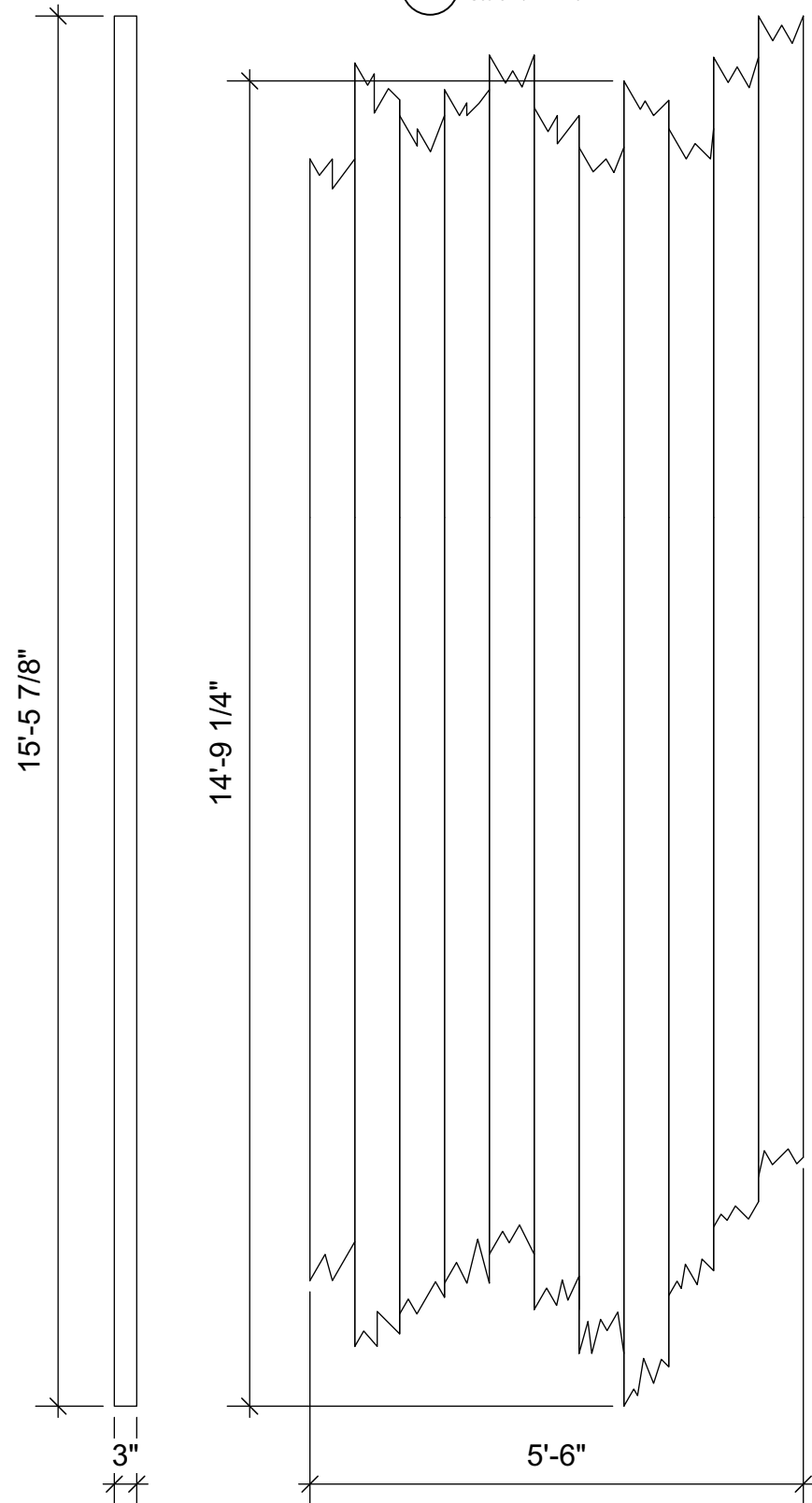
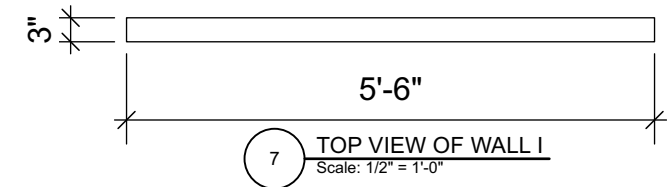
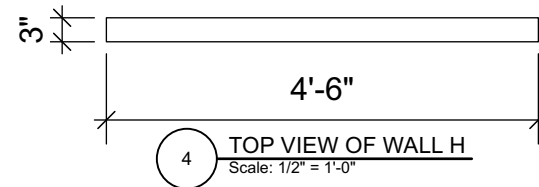
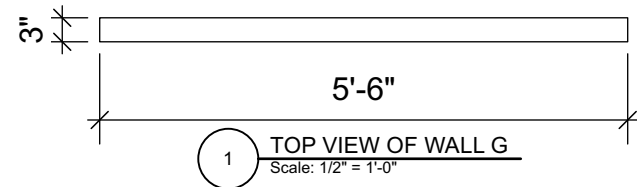



University of Alabama
School of Theatre and Dance
MARIAN GALLAWAY THEATRE

Teila Vochatzer
SCENIC DESIGNER

The Color Purple

WALLS A1-B2

Directed by

Lighting Designer

Sound Designer

Technical Director

Scale

1/2" = 1'

UNLESS OTHERWISE NOTED

General Notes

1. WALLS WILL BE SMOOTH WOOD & PAINTED TO LOOK WORN & ROUGH.
2. WOOD SHOULD BE CUT OR BROKEN TO LOOK ROUGH ON EDGES.
3. WALLS WILL ACT AS LEGS & BE AFIXED TO THE STAGE FLOOR.

This drawing is confidential. The reproduction or use of ideas, arrangements, designs, and plans are prohibited without written consent of Teila Vochatzer.

Written dimensions will always override scale should a conflict arise.

Responsibility falls solely on the vendors to notify Teila Vochatzer of any discrepancies between this drawing and actual dimensions.

This drawing represents concepts and suggestions only. The design team is not responsible nor held liable for the structural, mechanical or electrical execution of this drawing. Any structural components within this drawing must be approved by a qualified engineer before installation begins. Furthermore any other work done is to be performed by qualified personnel only.

Equipment and installation must conform to all local and federal codes and fire safety regulations.

Plate No.

9 of 10

September 28, 2021

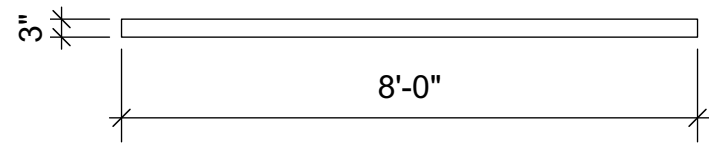

1 TOP VIEW OF WALL A1
Scale: 3/8" = 1'-0"

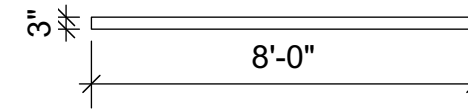

7 TOP VIEW OF WALL B1
Scale: 1/4" = 1'-0"

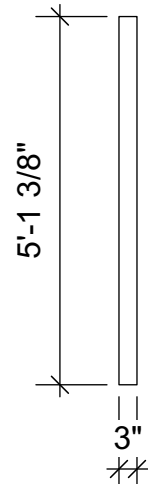

2 SIDE VIEW OF WALL A1
Scale: 3/8" = 1'-0"

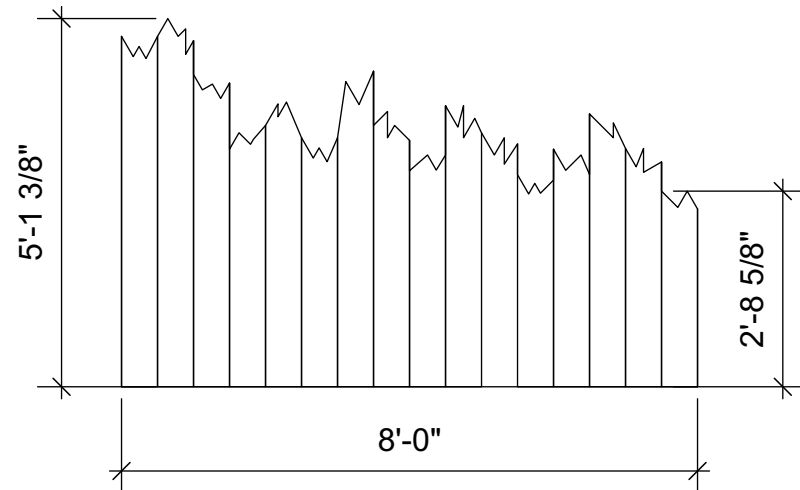

3 FRONT VIEW OF WALL A1
Scale: 3/8" = 1'-0"



8 SIDE VIEW OF WALL B1
Scale: 1/4" = 1'-0"

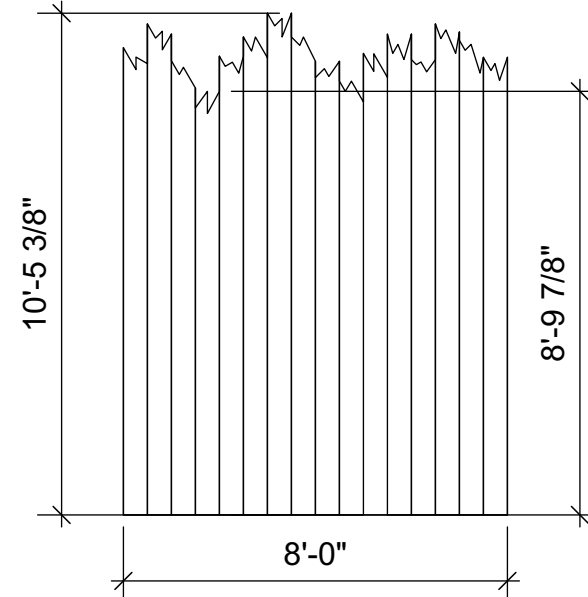

9 FRONT VIEW OF WALL B1
Scale: 1/4" = 1'-0"

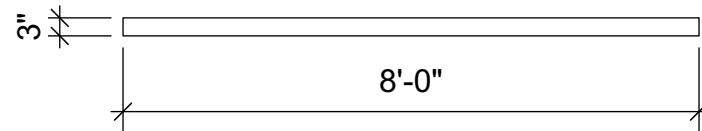

4 TOP VIEW OF WALL A2
Scale: 3/8" = 1'-0"

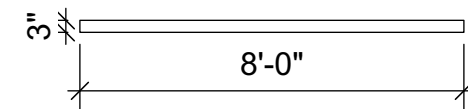

10 TOP VIEW OF WALL B2
Scale: 1/4" = 1'-0"



5 SIDE VIEW OF WALL A2
Scale: 3/8" = 1'-0"

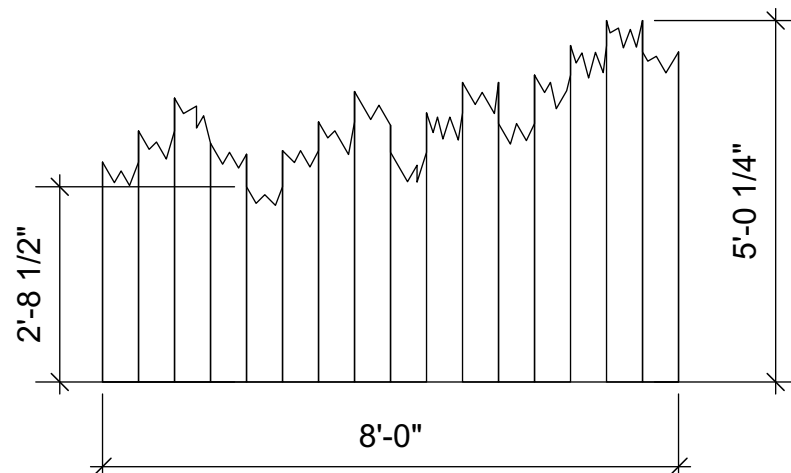

6 FRONT VIEW OF WALL A2
Scale: 3/8" = 1'-0"

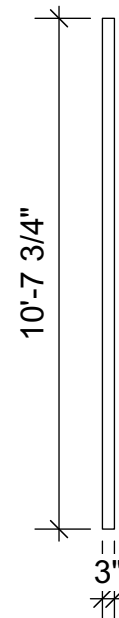

11 SIDE VIEW OF WALL B2
Scale: 1/4" = 1'-0"

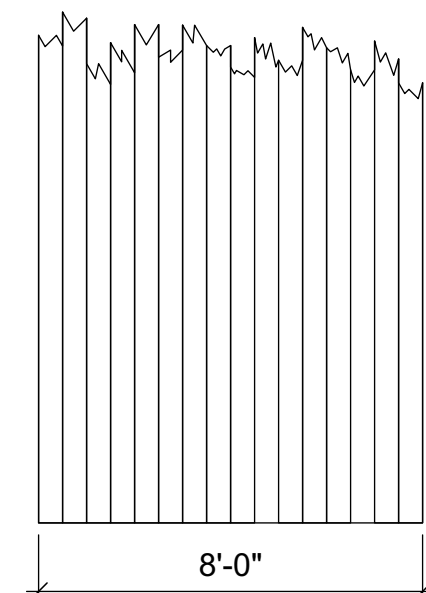

12 FRONT VIEW OF WALL B2
Scale: 1/4" = 1'-0"



University of Alabama
School of Theatre and Dance
MARIAN GALLAWAY THEATRE

Teila Vochatzer
SCENIC DESIGNER

The Color Purple
WALLS C1-D2

Directed by

Lighting Designer

Sound Designer

Technical Director

Scale
3/16" = 1'

General Notes

1. WALLS WILL BE SMOOTH WOOD & PAINTED TO LOOK WORN & ROUGH.
2. WOOD SHOULD BE CUT OR BROKEN TO LOOK ROUGH ON EDGES.
3. WALLS WILL ACT AS LEGS & BE AFIXED TO THE STAGE FLOOR.

This drawing is confidential. The reproduction or use of ideas, arrangements, designs, and plans are prohibited without written consent of Teila Vochatzer.

Written dimensions will always override scale should a conflict arise.

Responsibility falls solely on the vendors to notify Teila Vochatzer of any discrepancies between this drawing and actual dimensions.

This drawing represents concepts and suggestions only. The design team is not responsible nor held liable for the structural, mechanical or electrical execution of this drawing. Any structural components within this drawing must be approved by a qualified engineer before installation begins. Furthermore any other work done is to be performed by qualified personnel only.

Equipment and installation must conform to all local and federal codes and fire safety regulations.

Plate No.

10 of 10

Septemeber 28, 2021

